

**Vectrex™**  
GRAPHIC COMPUTER SYSTEM

**BEDLAM™**

**GCE™**  
A Milton Bradley Company

©General Consumer Electronics, Inc. 1983. Santa Monica, CA 90401. All Rights Reserved.

A copyright protection is claimed on the program stored within the cartridge.



**BEDLAM™**

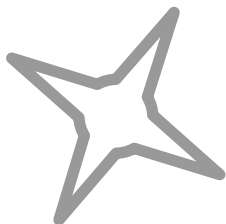

Your home galaxy has been invaded by alien colonists hoping to claim all inhabited worlds as their own.

Unacceptable!

You have been given the ultimate responsibility of protecting your galactic neighbors from the invaders.

Blasting the aliens with the amazing anti-molecular cannon transports them thousands of light years away where they will cause no further bedlam. But beware, the invaders will be increasingly ruthless.

The future of the galaxy rests on your shoulders. Good luck!



# Setting Up

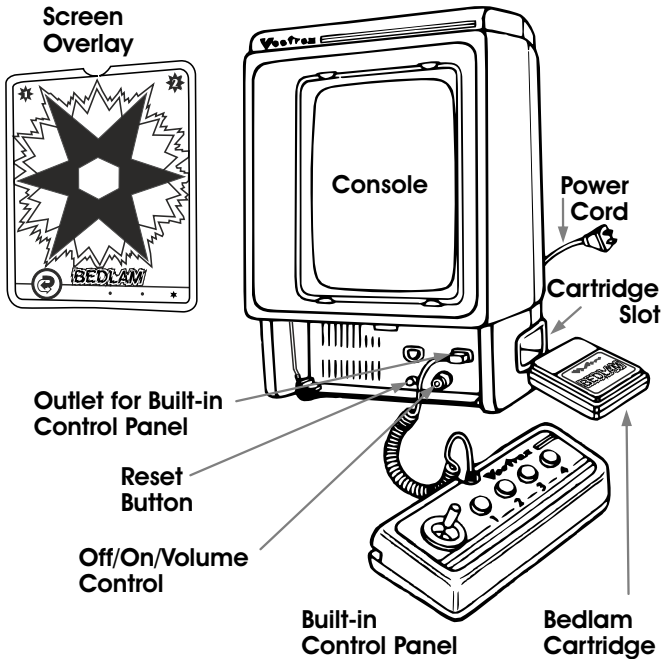

- Make sure the console power cord is plugged into a 120 volt AC 60 cycle electrical outlet.
- Check to be sure the plug for the built-in control panel is firmly seated in the control panel outlet on the right.
- **MAKE SURE THE CONSOLE IS TURNED OFF BEFORE INSERTING THE CARTRIDGE.** Insert the cartridge into the cartridge slot with the label side up. Be sure it is firmly inserted to the guideline marked on the cartridge.
- Insert the screen overlay behind the tabs at the top and bottom of the screen.
- Turn the OFF/ON/VOLUME CONTROL to the ON position (clockwise). You will see the Vectrex title for a few seconds, then the name of the game.
- Adjust the volume control to the desired listening level.

## Bedlam Controls

Bedlam is played with the built-in control panel only. The functions of the controls are:

Rotates your cannon.  
Pushing to the right rotates clockwise.  
Pushing to the left rotates counter-clockwise.

### Zap

Removes all aliens in a pattern. Only one zap per pattern. (Also used to select starting skill level — 1, 2, or 3.)

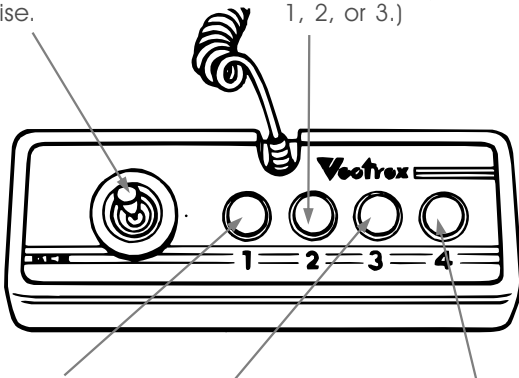

**Number of players**  
Selects one or two player game. Also acts as FAST ROTATE during game play.

**Fast Rotate**  
Increases speed of cannon rotation while pushing joystick.

**Fire**  
Activates the anti-molecular cannon.

## How To Play

### Player Selection

Bedlam can be played as either a one or two player game. When **PLAYER** appears on the screen, press



1  
GAME  
1

Button 1 once to switch to a two player game.

**PLAYER** will then be displayed on the screen.



2  
GAME  
1

When played as a two player game, use only the built-in control panel and simply take turns with the controls. You can return to a single player game by pressing Button 1 again before starting game play.

### Skill Level Selection

You can begin the Bedlam game at any of three different skill levels. Level 1 is the least difficult; Level 3 is the most difficult. To select the skill level, push Button 2. This option allows you to skip past levels you have already mastered.

### Starting Game Play

Once you have selected the number of players and the skill level, press Button 4 to enter the first galactic sector and begin game play.

## **Game Play**

As the game begins, you find yourself at the center of the first galactic sector. From the far corners of the sector, the alien colonists begin their attack moving directly toward your position. Rotate the direction of the cannon by using the Joystick. For faster rotation, press Button 3 and move the Joystick at the same time. As the aliens come within range, fire with Button 4. If it becomes impossible to maintain a controlled defense, you are allowed to ZAP all the aliens at once by pressing Button 2. However, you are only allowed to use the Zap one time in each sector.

After you have cleared a sector of alien invaders, you will be immediately transported to a different part of the galaxy. Each new sector will be more challenging, with increasingly aggressive aliens.

## **Cannons**

You are provided with three anti-molecular cannons per game and unlimited ammunition. One extra cannon will be earned for every 10,000 points you score. Although you may earn a large number of extra cannons, the greatest number that will be displayed at the bottom of the screen will be eight, any number over eight will still be available for use.

## **Direct Hits**

Your cannon will be destroyed whenever an alien is allowed to make direct contact. After a hit, you will



be returned to the same galactic sector where you must eliminate the remaining aliens before advancing to the next sector.

## **Galactic Sectors**

The shape and challenge of each sector will change during the game. As you progress to more difficult levels in the game, sectors will rotate, shrink, and pulsate.

## **Alien Types and Characteristics**

### **Escort Ships**

These alien ships surround the colonists' space armada and will be present in each sector. Escort ships will approach your cannon directly without pausing.

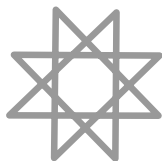

### **Astral Defenders**

Special star ships in the invaders' armada that direct the defense activities of the aliens. They will approach your cannon only when it's pointed in another direction and you are vulnerable to attack.



## Droids

Deadly unmanned star ships that have been programmed by the aliens to seek out and destroy any force unfriendly to the colonists. The Destroyer Droids will circle your cannon waiting to destroy you at your most vulnerable moment.

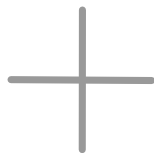

## Colonist Transports

These star ships hold the civilian colonists. Because of their powerful shields, they can never be directly blasted out of your galaxy, but you do gain points each time you score a direct hit. Direct hits force the Transports back to the farthest reaches of each sector, but they will return. These ships remain in each sector until all other ships are removed.



## Scoring

Points are awarded for blasting aliens in the galactic sectors as follows:

Alien Type	Points
Escort Ships	75
Astral Defenders	100
Destroyer Droids	150
Colonist Transports	175

## Highscore Memory

As long as your machine is on, with the Bedlam cartridge in place, the high score is retained. Once the machine is turned off and the cartridge removed, the high score is lost. To check the high score, press the Reset Button on the console.

## Restarting Game

To restart after a completed game with the same number of players, simply push Buttons 1, 2 or 3.



## Score Record

Date	Name	Score
_____	_____	_____
_____	_____	_____
_____	_____	_____
_____	_____	_____
_____	_____	_____
_____	_____	_____
_____	_____	_____
_____	_____	_____
_____	_____	_____
_____	_____	_____
_____	_____	_____
_____	_____	_____
_____	_____	_____
_____	_____	_____
_____	_____	_____
_____	_____	_____
_____	_____	_____
_____	_____	_____
_____	_____	_____
_____	_____	_____
_____	_____	_____
_____	_____	_____
_____	_____	_____
_____	_____	_____
_____	_____	_____
_____	_____	_____

**Score Record**

**Date**

**Name**

**Score**

## 90 Day Limited Warranty

This GCE Video Game Cartridge is warranted by General Consumer Electronics, Inc. to the original consumer purchaser in the U.S.A. for a period of 90 days from the original purchase date under normal use and service against defective workmanship and materials. ANY IMPLIED WARRANTIES ARE ALSO LIMITED IN DURATION TO THE NINETY (90) DAY PERIOD FROM THE ORIGINAL PURCHASE DATE. SOME STATES DO NOT ALLOW LIMITATIONS ON HOW LONG AN IMPLIED WARRANTY LASTS, SO THE ABOVE LIMITATION MAY NOT APPLY TO YOU.

This warranty is void if the Video Game Cartridge has been damaged by accident, unreasonable use, neglect, misuse, abuse, improper service, modification, subject to commercial use or other causes not arising out of defects in workmanship or materials and is limited to electronic and mechanical parts contained in the cartridge.

GENERAL CONSUMER ELECTRONICS, INC. SHALL NOT BE LIABLE FOR LOSS OF USE OF THE VIDEO GAME CARTRIDGE OR OTHER INCIDENTAL OR CONSEQUENTIAL COSTS. EXPENSES OR DAMAGES INCURRED BY THE PURCHASER RESULTING FROM BREACH OF ANY EXPRESS OR IMPLIED WARRANTIES ON THE VIDEO GAME CARTRIDGE. SOME STATES DO NOT ALLOW THE EXCLUSION OR LIMITATION OF INCIDENTAL OR CONSEQUENTIAL DAMAGES. SO THE ABOVE LIMITATION OR EXCLUSION MAY NOT APPLY TO YOU.

During the warranty period, if found to be defective due to workmanship or materials, the Video Game Cartridge will at the option of General Consumer Electronics, Inc. be repaired or replaced with a new or reconditioned Video Game Cartridge without charge for parts or labor when returned by Purchaser with proof of purchase date, shipped prepaid to General Consumer Electronics, Inc. at the following address: **General Consumer Electronics, Inc. 520 Broadway, Suite 600, Santa Monica, CA 90401.**

In the event that your Video Game Cartridge is replaced, the warranty on the replacement will be ninety (90) days from the date of its return to you.

# Order Form for Replacement Screen Overlays

Additional screen overlays may be ordered by completing this form and mailing it with your check or money order for \$2.00 each.

Address check or money order to:

**GCE, Vectrex Screen Overlays, P.O. Box 8123,  
San Francisco, CA 94128**

Please allow 2-3 weeks for delivery. Offer subject to availability.

**Note: Separate cartridges are needed for the overlays listed below.**

## SCREEN OVERLAY

Mine Storm	Solar Quest	Spike
Armor Attack	Space Wars	SpinBall
Berzerk	Star Hawk	Web Wars
Clean Sweep	Star Trek	Pole Position
Hyperchase	Blitz!	Dark Tower
Cosmic Chasm	Heads-Up	Star Castle
Rip-Off	Fortress of Narzod	Others _____
Scramble	Bedlam	(specify)

## SCREEN

**OVERLAY** (fill in)                      **QUANTITY** (fill in)                      **COST** (fill in)

_____	_____	@ \$2.00 \$
_____	_____	@ \$2.00
_____	_____	@ \$2.00
_____	_____	@ \$2.00
_____	_____	@ \$2.00
_____	_____	@ \$2.00

Total Overlays Ordered                      Total Costs \$

Calif. Residents Add 6% Sales Tax                      \$

Total Amount Enclosed                      \$

Name \_\_\_\_\_ Phone (    ) \_\_\_\_\_

Address \_\_\_\_\_

City \_\_\_\_\_ State \_\_\_\_\_ Zip \_\_\_\_\_

**Vectrex™**  
GRAPHIC COMPUTER SYSTEM

**GCE™**  
A Milton Bradley Company

9872N-033